

# Processing Three Types of Korean Cleft Constructions in a Typed Feature Structure Grammar

Jong-Bok Kim<sup>1</sup> and Jaehyung Yang<sup>2</sup>

<sup>1</sup> School of English, Kyung Hee University, Seoul, 130-701, Korea  
jongbok@khu.ac.kr

<sup>2</sup> School of Computer Engineering, Kangnam University, Kyunggi, 446-702, Korea  
jhyang@kangnam.ac.kr

**Abstract.** The expression KES, one of the most commonly used words in the Korean language, has various usages. This expression is also used to express English-like cleft constructions. Korean seems to employ at least three different types of cleft constructions: predicational, identificational, and eventual. The paper tries to provide a constraint-based analysis of these three types of Korean cleft constructions and implement the analysis in the LKB system to check the feasibility of the analysis. In particular, the paper shows how a typed feature structure grammar, couched upon HPSG, can provide a robust basis for parsing Korean cleft constructions.

Key words: KES, cleft, computational implementation, predicational, identificational

## 1 Introduction

Cleft constructions are employed to mark a certain constituent as a discourse prominent element.<sup>3</sup> In this respect, Korean has at least three main types of clefts:<sup>4</sup>

- (1) a. Predicational:  
[John-i \_\_\_ i ilk-un kes-un] [kacca]<sub>i</sub>-i-ta  
John-NOM read-MOD KES-TOP fake-COP-DECL  
'What John read is a fake.'
- b. Identificational:  
[i chayk]<sub>i</sub>-i palo [John-i \_\_\_ i ilk-un kes-i-ta]  
this book-NOM very John-NOM read-MOD KES-COP-DECL  
'This book is what John read.'

<sup>3</sup> Much of the theoretical discussion follows from [?]. We thank anonymous reviewers of this journal for helpful comments. This work was supported by the Korea Research Foundation Grant (KRF-2005-042-A00056)

<sup>4</sup> See [?] and [?] for the distinction between predicational and identificational cleft.

- c. Eventual  
 kuttay [John-i cip-ey o-n] kes-i-ess-ta  
 the moment John-NOM home-LOC come-MOD KES-COP-PAST-DECL  
 ‘It is at the very moment that John came home.’

These three types of cleft mainly consist of a cleft clause, a pivot XP, and the copula verb. The predicational cleft in (1a) consists of a cleft clause with the missing object coindexed with the precopula expression *kacca* ‘fake’ whereas the identificational cleft in (1b) has the nominative phrase *i chayk* ‘this book’ as the pivot XP coindexed with the missing object in the following cleft clause. In these two clefts, the pivot XP is linked to the content of the cleft clause introduced by KES, though the exact semantic function is different. For example, in the predicational cleft (1a), the XP is predicated of the individual that the cleft clause refers to, whereas in the identificational one, the XP and the individual are in a identity relation. Meanwhile, in the event cleft, the whole clause preceding the KES expression is clefted, functioning as the pivot phrase. In this sense, the whole clause is focused. The structure of these three types of clefts can be schematized as follows:

- (2) a. Predicational:  $[[S \text{ } \_i \text{ } ]\text{-KES}]\text{-TOP XP}_i\text{-COP-DECL}$   
 b. Identificational:  $\text{XP}_i\text{-TOP}[S \text{ } \_i \text{ } ]\text{-KES-COP-DECL}$   
 c. Eventual:  $[[\text{adverbial}], [S \text{ 'saturated clause'}]\text{-KES}]\text{-COP-DECL}$

As represented here, both of the predicational and identificational have a pivot or highlighted expression like the English cleft constructions whereas in the event cleft it is the whole clause that seems to be clefted. The event clause is thus different from the other two in that the clause has no missing element.<sup>5</sup>

This paper aims to review the basic properties of these three different types of Korean cleft constructions and provide a constraint-based analysis. We also show a brief summary of the results of implementing this analysis in the LKB (Linguistic Knowledge Building) system ([?]).

## 2 Formal Properties of the Cleft Constructions

### 2.1 Predicational and Identificational Cleft

As observed, the cleft constructions mainly consist of a cleft clause, a focus element, and the copula. The canonical cleft clause, usually representing given or discourse-old information, has a syntactically missing element.<sup>6</sup> In this respect, Korean clefts behave like relative clauses, but differently from topic constructions which can be either gapped or gapless. Consider these three constructions:

<sup>5</sup> Some transformational analyses assume that the predicational and identificational clefts are derived from the eventual clefts. See [?] and [?].

<sup>6</sup> Much of the discussion in this section follows from [?] and [?].

- (3) a. ku chayk-un [John-i \_\_ ilk-ess-ta]  
 the book-TOP John-NOM read-PAST-DECL  
 ‘This book, John read.’  
 b. kkoch-un [cangmi-ka yepputa]  
 flowers-TOP rose-NOM pretty  
 ‘As for flowers, roses are pretty.’
- (4) a. [John-i \_\_ ilk-un] ku chayk  
 John-NOM read-MOD the book  
 ‘the book that John read’  
 b. \*[John-i ku sosel-ul ilk-un] ku chayk  
 John-NOM the novel-ACC read-MOD the book
- (5) a. [John-i \_\_ ilk-un kes]-un palo i chayk-i-ta  
 John-NOM read-MOD KES-TOP very this book-COP-DECL  
 ‘What John read is this very book.’  
 b. \*[John-i ku sosel-ul ilk-un kes]-un palo i chayk-i-ta  
 John-NOM the novel-ACC read-MOD KES-TOP very this book-COP-DECL

As illustrated here, the topic construction can have either a gap or a non-empty gap whereas the relative clause and cleft construction requires its clause to have a missing gap element. In this sense, clefts are like relative clauses, rather than topic clauses.

As for the possible type of the pivot or focus phrase, in the predicational copula, the focused XP can be either an argument or an adjunct. The postposition or semantic marker of the focused expression is optional:

- (6) a. [John-i Mary-lul manna-n kes]-un [kongwen-(eyse)]-i-ta  
 [John-NOM Mary-ACC meet-MOD KES]-TOP park-at-COP-DECL  
 ‘It was at the park that John met Mary.’  
 b. John-i Mary-lul manna-n kes-un [tosekwan-(eyse)]-i-ta  
 John-NOM Mary-ACC meet-MOD KES-TOP library-at-COP-DECL  
 ‘Where John met Mary is (at) the library.’  
 c. swum-i taptapha-n kes-un [sanso-ka pwucokhayse]-i-ta  
 breath-NOM choking-MOD KES-TOP oxygen-NOM short.do-COP-DECL  
 ‘Because of lack of oxygen, it is hard to breathe.’  
 d. John-i Mary-eykey senmwul-ul cwu-n kes-un [wupyen-(ulo)]-i-ta  
 John-NOM Mary-DAT present-ACC give-MOD KES-TOP mail-by-COP-DECL  
 ‘The way John gave Mary a present is by mail.’

In the predicational cleft, an adverbial element also can be focused as long as it is categorically nominal:<sup>7</sup>

- (7) John-i Mary-lul manna-n kes-un [ecey]-i-ta  
 John-NOM Mary-ACC meet-MOD KES-TOP yesterday-COP-DECL  
 ‘It is yesterday when John met Mary.’

<sup>7</sup> However, true adverbs cannot be focused:

John-i Mary-lul manna-n kes-un [siksa-lul ha-ko nase]-i-ta  
 John-NOM Mary-ACC met-MOD KES-TOP meal-ACC do-COMP after-COP-DECL  
 ‘It is after having a meal when John met Mary.’

Meanwhile, the identificational cleft does not allow the PP adjunct to be focused, regardless of the presence of the postposition:

- (8) a. \*[kongwen-(eyse)]<sub>PP</sub>-ka [John-i Mary-lul manna-n kes]-i-ta  
           park-at-NOM [John-NOM Mary-ACC meet-MOD KES]-COP-DECL  
 b. \*[sanso-ka pwucokhayse]-ka swum-i taptapha-n kes-i-ta  
           oxygen-NOM short.do-NOM breath-NOM choking-MOD KES-COP-DECL  
 c. \*[tosekwan-(eyse)]-ka John-i Mary-lul manna-n kes-i-ta  
           library-at-NOM John-NOM Mary-ACC meet-MOD KES-COP-DECL  
 d. \*[ecey]-ka John-i Mary-lum manna-n kes-i-ta  
           yesterday-NOM John-NOM Mary-ACC meet-MOD KES-COP-DECL

This indicates that unlike the predicational cleft, the identificational cleft allows only an NP argument to serve as its XP focus.

The gapped element in the cleft clause can be in the embedded clause, allowing a long dependency relationship between the gap and the linked XP:

- (9) a. [John-i [Mary-ka \_\_ cohahanta-ko] sayngkakha-nun kes]-un  
           John-NOM Mary-NOM like-COMP think-MOD KES-TOP  
           i kulim-i-ta  
           this picture-COP-DECL  
           ‘What John thought Mary likes is this picture.’  
 b. i kulim-i [John-i [Mary-ka \_\_ cohaha-n-ta-ko]  
           this picture-NOM John-NOM Mary-NOM like-PRES-DECL-COMP  
           sayngkakha-nun kes]-i-ta  
           think-MOD KES  
           ‘This picture is what John thought Mary likes.’

In both predicational and identificational clefts, the pivot phrase *i kulim* ‘this picture’ is linked to the object of the embedded clause. This pivot XP, however, cannot be an adjunct in the embedded clause. This is once again similar to relative clauses:

- (10) a. [John-i [Mary-ka ku chak-ul ilkessta-ko]] sayngkakha-n ecey  
           John-NOM Mary-NOM the book-ACC read-COMP think-MOD yesterday  
           ‘the time when John thought Mary read the book’

- 
- (i) a. \*John-i talli-n kes-un [chenchenhi]-i-ta  
           John-NOM run-MOD KES-TOP slowly-COP-DECL  
           ‘(lit.) The way John ran was slowly.’  
 b. \*[chenchenhi]-ka John-i talli-n kes-i-ta  
           slowly-NOM John-NOM run-MOD KES-COP-DECL

As noted here, neither the predicational nor identificational cleft allows a true adverb to be focused.

- b. [John-i [Mary-ka ku chak-ul ilkessta-ko] sayngkakha-nun kes]-un  
 John-NOM Mary-NOM the book-ACC read-COMP think-MOD KES-TOP  
 ecey-i-ta  
 yesterday-COP-DECL  
 ‘The time when John thought Mary read the book was yesterday’

In both relative and cleft examples here, the relativized and cleft adjunct is linked to the higher main clause, not to the embedded clause.

We can further observe that just like relative clauses, the cleft observes the CNPC (complex noun phrase constraint):

- (11) a. [John-i \_\_ piphanha-n kes-un] ku nonmwun-i-ta  
 John-NOM criticize-MOD KES-TOP the article-COP-DECL  
 ‘What John criticized is the article.’  
 b. \*[John-i [[\_\_ ssu-n] salam-ul]] piphanha-n] kes-un ku nonmwun-i-ta  
 John-NOM write-MOD person-ACC criticize-MOD KES-MOD the article-COP-DECL  
 ‘(lit.) What John criticized the person who wrote \_\_ was the article.’

This indicates that the cleft clause introduced by KES behaves like a nominal clause that forms an island even though internally it is a clause.

## 2.2 Eventual Cleft Constructions

Unlike the predicational and identificational constructions, KES can nominalize a whole preceding S, highlighting an event, as in (12).<sup>8</sup>

- (12) a. [ku ttay] [sako-ka na-n] kes-i-ya  
 that moment accident-NOM happen-PAST KES-COP-DECL  
 ‘It is at that moment that an accident happened.’  
 b. [ku yeca-ka John-ul manna-n] kes-i-ya  
 that woman-NOM John-ACC meet-PAST KES-COP-DECL  
 ‘The fact is that [that woman met John].’

Such an event cleft cannot be used discourse initially:

- (13) cal iss-ess-e? nay-ka tola o-ass-e/\*o-n ke-ya  
 well exist-PAST-Q I-NOM return come-PAST-DECL  
 ‘How have you been? I came back’

<sup>8</sup> It is possible to present the new information as a canonical VP:

- (i) chelwsu-nun [onul hyuil-i-nci moll-ass-ten kes]-i-ess-ta  
 Chelsoo-TOP [today holiday-COP-COMP not.know-PAST-MOD KES]-COP-PAST-DECL  
 ‘The fact is that Chelsoo did not know that today is a holiday.’

Intuitively, this VP focus example presents a noteworthy fact about a given individual.

This kind of cleft construction conveys the meaning of ‘cause, reason, explanation, or consequence’, focusing the information in the cleft clause.<sup>9</sup> Notice that there is no syntactic gap in the event clause. The clause also is all presented as new information, as can be attested by the fact that these examples can be an appropriate answer to a question like (14):<sup>10</sup>

- (14) mwusun il-i-ni?  
 what thing-COP-Q  
 ‘What happened?’

Unlike the predicational and identificational ones, the KES in the event cleft cannot be replaced by a common noun:

- (15) a. ku ttay sako-ka na-n kes/\*iyu-i-ta  
 then accident occur-MODKES/reason-COP-DECL  
 ‘And then the accident occurred.’  
 b. kuliko nase hyung-i os-ul twici-nun kes/\*swunkan-i-ess-ta  
 and then brother-NOM clothes-ACC search-MOD KES/moment-COP-PAST-DECL  
 ‘And then, brother was searching the clothes.’

In addition, the cleft clause induces a freezing effect in that no element can be extracted out of the clause. For example, relativization is disallowed from the event cleft clause:

- (16) a. os-ul twici-n hyung  
 clothes-ACC search-MOD brother  
 ‘brother who is searching the clothes’  
 b. chakha-n haksayng-i-n hyung  
 honest-MOD student-COP-MOD brother  
 ‘the bother who is honest’  
 c. \*kuliko nase os-ul twici-nun kes-i-n hyung  
 and then clothes-ACC search-MOD KES-COP-MOD brother

### 3 Syntax and Semantics of the Cleft Constructions

#### 3.1 Predicational and Identificational Cleft

The observations we have seen in the previous section have shown us that the cleft clause exhibits nominal properties externally though it displays verbal properties internally. With the aim of implementing the analysis for computational

<sup>9</sup> We leave out the exact semantic and pragmatic functions of this construction.

<sup>10</sup> Any phrase within the event cleft can have a narrow focus interpretation with a phonological prominence on it.

- (i) a. kuliko nase HYUNG-I os-ul twici-nun kes-i-ess-ta  
 and then brother-NOM clothes-ACC search-MOD KES-COP-PAST-DECL  
 ‘And then my brother was searching the clothese.’  
 b. kuliko nase hyung-i OS-ul twici-nun kes-i-ess-ta  
 c. kuliko nase hyung-i os-ul TWICI-NUN kes-i-ess-ta

purposes, the challenges are thus how we capture these mixed properties with less stipulations.

The first issue in processing cleft constructions concerns the categorical status of KES. Consider the main uses of KES:

- (17) a.    *nay kes-i        ne kes-pota        khu-ta*  
           my thing-NOM your thing-more big-DECL  
           ‘(Lit.) My thing is bigger than your thing.’
- b.    *[[John-i    \_\_ mek-un] kes]-ul    mek-ess-ta*  
           John-NOM    eat-MOD KES-ACC eat-PAST-DECL  
           ‘(We) ate the thing that John ate.’
- c.    *[[John-i    talli-nun] kes]-ul    moll-ass-ta*  
           John-NOM run-MOD KES-ACC not.know-PAST-DECL  
           ‘(We) didn’t know that John was running.’

As noted here, KES in (17a) combines with a specifier whereas the one in (17b) combines with the relative clause with one missing argument. In both of these examples, KES refers to a ‘thing’. Meanwhile, KES in (17c) combines with a complete sentence, referring to the event denoted by the clause.<sup>11</sup> In terms of meaning, we can assume KES to have at least the following two lexical entries:

- (18) a.    
$$\left[ \begin{array}{l} cn \\ \langle kes \rangle \\ SYN \left[ \begin{array}{l} HEAD | POS \textit{noun} \\ VAL | SPR \langle \langle (DetP) \rangle \rangle \end{array} \right] \\ SEM \left[ \begin{array}{l} INDEX \textit{i} \\ RELS \langle \langle [PRED \textit{one\_rel}] \rangle \rangle \end{array} \right] \end{array} \right]$$
- b.    
$$\left[ \begin{array}{l} bn \\ \langle kes \rangle \\ SYN \left[ \begin{array}{l} HEAD \left[ \begin{array}{l} POS \textit{noun} \\ NFORM \textit{kes} \end{array} \right] \\ VAL | COMPS \langle \langle S \left[ \begin{array}{l} GAP \langle \rangle \rangle \\ IND \textit{e1} \end{array} \right] \rangle \rangle \end{array} \right] \\ SEM | INDEX \textit{e1} \end{array} \right]$$

The lexical entry (18a) means that KES refers to an individual equivalent to the meaning of *one* and combines with an optional DetP.<sup>12</sup> This kind of treatment, in which KES is taken to be a type of common noun diverges from the traditional

<sup>11</sup> In the literature, KES in (17c) has been treated as a complementizer. Cf. [?] and [?].

<sup>12</sup> Though it may be premature to link KES with the substitute pronoun *one*, there exist many cases where the two behave similar (cf. Quirk et al. 1985):

view treating KES as only a bound noun. Corpus data reveal that KES can be used like a common noun in various contexts:

- (19) saylowun siswul-ul hanta-ko, yatan-i-ess-nuntey. kes-to chwisotoy-ess-e.  
 new operation-ACC do-COMP lowsy-COP-PAST-but, KES-also cancel-PAST-DECL  
 ‘People were talking about the new way of operation, but it was also canceled.’ (Sejong Corpus)

This in turn means that we predict examples like the following:

- (20) [John-i \_\_ ilk-un kes/ku kes]-ul **ilk-ess-ta**  
 John-NOM read-MOD KES/the KES-ACC read-PAST-DECL  
 ‘(We) read the thing that John ate.’

Like other common nouns, the expression KES, regardless of combining with its specifier or not, can thus be modified by the relative clause.

Unlike such a common noun KES the lexical entry for KES in (18b) specifies that KES is a bound noun, selecting a saturated sentence. In this case, its INDEX value is identified with that of the sentential complement, insuring that KES denotes an event.<sup>13</sup> One clear example where KES is linked to an event can be found from an example like the following:

- (21) [John-i sakwa-lul mek-un kes-ul] moll-ass-ta  
 John-NOM apple-ACC eat-MOD KES-ACC not.know-PAST-DECL  
 ‘(He) didn’t know that John ate an apple.’

Here the argument of predicate ‘not.know’ is the sentence introduced by KES, similar to the English complementizer *that*. In this sense we can assume that KES denotes an event identified with its sentential complement.

Now let’s consider the following relative clause and predicative cleft example, respectively:

- (22) a. [John-i \_\_ mek-un kes/sakwa]-ul **mek-ess-ta**  
 John-NOM eat-MOD KES/apple-ACC eat-PAST-DECL  
 ‘(We) ate the thing that John ate.’  
 b. [John-i \_\_ mek-un kes/kwail]-un **sakwa-i-ta**  
 John-NOM eat-MOD KES/fruit-TOP apple-COP-DECL  
 ‘What John ate is an apple.’

- 
- (i) a. The one with chocolate frosting has cream filling.  
 b. Is this the one you want to meet?  
 c. Do you want these ones?  
 d. These donuts look delicious; I think I will choose this one.

The expression *one* here can refer to an entity as well as a human; it can be pluralized; it can be a member of the set in the given context.

<sup>13</sup> The bound noun KES also has the NFORM value. See the discussion of event cleft for its use.

The only difference we can observe here is the predicate. The sentence with a relative clause has a transitive verb whereas the one with a cleft clause has a copula. As we have seen earlier, both the relative and cleft clause are identical in the sense that each clause has a syntactic gap here. In both cases, KES can be replaced by a common noun, indicating that there is no semantic difference. Let's consider the structure of (22a) with a relative clause first:

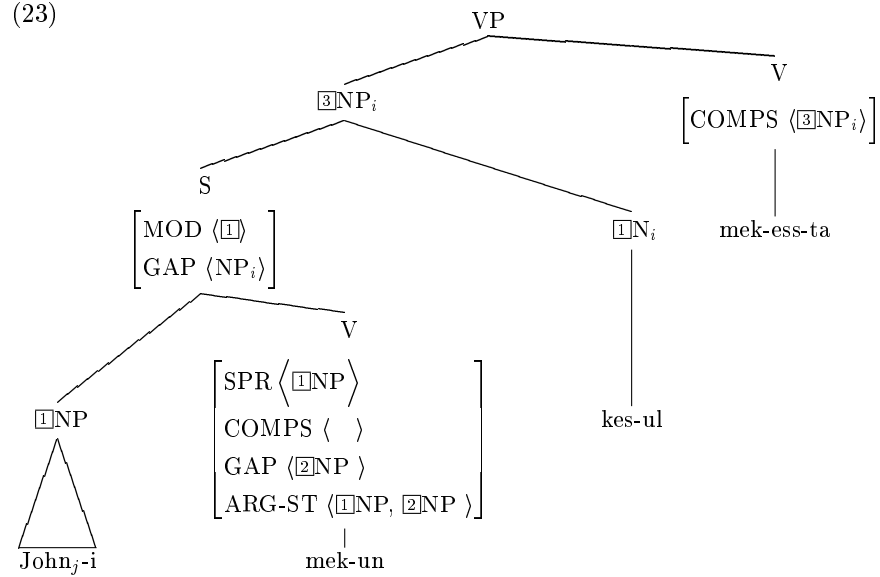

As we noted here, the noun KES in relative clauses is a common noun referring to an individual: this information is passed up to the NP projection (the index value 'i'). Since the verb *mek-un* 'ate' also requires its object to be a referential individual, there is no mismatch between these two requirements. To observe how we obtain the semantics correctly, let us consider the shorthand MRS (minimal recursion semantics) representation of this NP.<sup>14</sup>

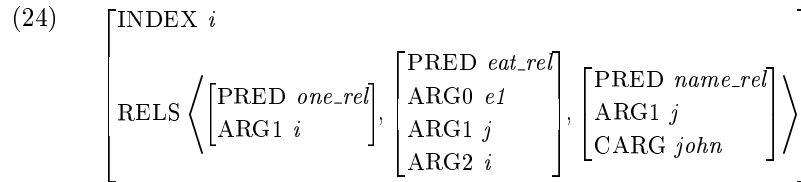

<sup>14</sup> Minimal Recursion Semantics, developed by [?], is a framework of computational semantics designed to enable semantic composition using only the unification of type feature structures. See [?] and [?]. The value of the attribute SEM(ANTICS) in our system represents a simplified MRS. Also see [?] for the analysis of Korean relative clauses. ARG0 canonically refers to the index value of the EP (elementary predicate) itself whereas ARG1 or ARG2 refers to the predicate's semantic arguments. CARG refers to constant arguments whose value can be a name.

This semantic representation simply means that there is an individual ‘i’ which the person named John eats. This index value is linked to the ARG1 value of ‘one’ coming from KES. This index value is the semantic head information visible at the NP level, functioning as the object of the matrix clause.

How about the predicative cleft sentence? Before we provide its structure, consider the lexical entry for the copula *i-ta*. We have seen that there are two different cleft constructions. This leads us to assume that there are two different copula uses: predicational and identificational (also see ([?])). The difference of these two different copulas is represented in the following lexical entries:

- (25) a. Predicational Copula:
- $$\left[ \begin{array}{l} \langle i-ta \rangle \\ \text{ARG-ST} \langle \text{NP}_i, \text{XP}_j [\text{PRD } +] \rangle \\ \text{SEM | RELS} \langle \left[ \begin{array}{l} \text{PRED } \textit{predicative\_rel} \\ \text{ARG1 } i \\ \text{ARG2 } j \end{array} \right] \rangle \end{array} \right]$$
- b. Identificational Copula:
- $$\left[ \begin{array}{l} \langle i-ta \rangle \\ \text{ARG-ST} \langle \text{NP}_i, \text{NP}_j \rangle \\ \text{SEM | RELS} \langle \left[ \begin{array}{l} \text{PRED } \textit{identity\_rel} \\ \text{ARG1 } i \\ \text{ARG2 } j \end{array} \right] \rangle \end{array} \right]$$

The predicational copula in (25a) requires its second argument to carry the positive PRD feature, ensuring that this expression predicates of the first argument (subject). The semantics also reflects this. Meanwhile, the identificational copula in (25b) requires the INDEX value of the first argument is in the *identity\_rel* with that of the second argument. This lexical specification implies that the two expressions here have identical referential types.

Given these, we then can generate a structure like (26) for the predicational cleft (1a):

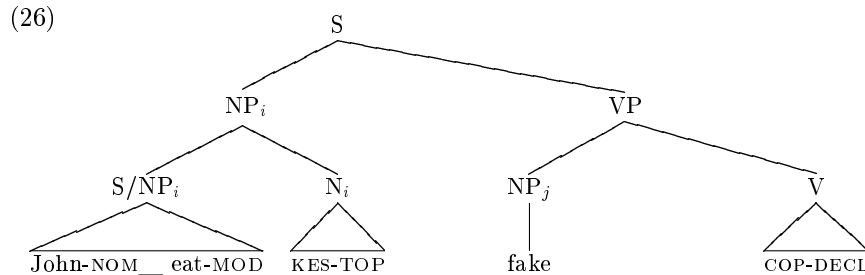

This structure, including the cleft clause as the subject and the predicative expression, will then induce the meaning similar to (25a). The predicative ex-

pression ‘fake’ will predicate of this nominal element, inducing a semantic representation like the following:<sup>15</sup>

$$(27) \left[ \text{RELS} \left\langle \left[ \begin{array}{l} \text{PRED } \textit{one\_rel} \\ \text{ARG0 } i \end{array} \right], \left[ \begin{array}{l} \text{PRED } \textit{fake\_rel} \\ \text{ARG1 } j \end{array} \right], \left[ \begin{array}{l} \text{PRED } \textit{predicative\_rel} \\ \text{ARG1 } i \\ \text{ARG2 } j \end{array} \right] \right\rangle \right]$$

The meaning of the copula *i-ta* is relevant to the variable missing in the cleft. This index value is ‘i’, which is in the *predicative* semantic relation with the index value of ‘fake’. This in turn means that as long as the precopular expression can be predicated of the cleft-clause subject, there is no categorial restriction on the type of the precopular expression. This is why we allow other than an NP in this position as we have seen before.

Now consider the structure of an identificational cleft sentence:

$$(28) \begin{array}{l} i \text{ sakwa-ka} \quad \text{John-i} \quad \text{mek-un} \text{ kes-i-ta} \\ \text{this apple-NOM} \quad \text{John-NOM} \quad \text{eat-MOD} \quad \text{KES-COP-DECL} \\ \text{‘This apple is what John ate.’} \end{array}$$

A simple tree representation will be something like the following:

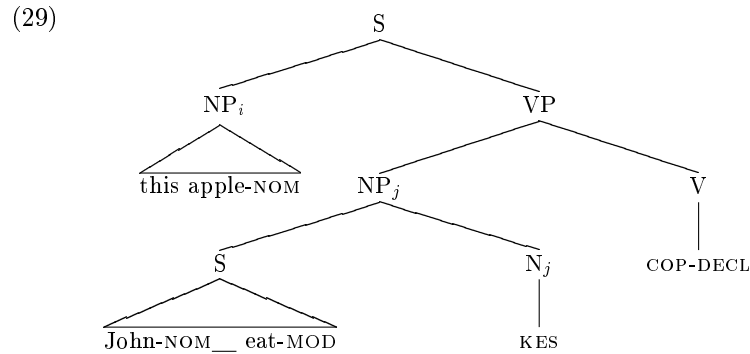

The lexical constraints of the identificational copula insure that the index value of the subject is identified with that of KES as represented in the expected semantics of this sentence:

$$(30) \left[ \text{RELS} \left\langle \left[ \begin{array}{l} \text{PRED } \textit{apple\_rel} \\ \text{ARG1 } k \end{array} \right], \left[ \begin{array}{l} \text{PRED } \textit{name\_rel} \\ \text{ARG1 } j \\ \text{CARG } \textit{john} \end{array} \right], \left[ \begin{array}{l} \text{PRED } \textit{eat\_rel} \\ \text{ARG0 } e1 \\ \text{ARG1 } j \\ \text{ARG2 } i \end{array} \right], \right. \\ \left. \left[ \begin{array}{l} \text{PRED } \textit{one\_rel} \\ \text{ARG1 } i \end{array} \right], \left[ \begin{array}{l} \text{PRED } \textit{identity\_rel} \\ \text{ARG1 } k \\ \text{ARG2 } i \end{array} \right] \right\rangle \right]$$

<sup>15</sup> The index value of a predicative expression is identified with that of the gapped element in the cleft clause.

Unlike the predicational one, the identificational one thus requires the identity of two index values. This is why neither the PP or an adverbial element can occur as the pivot XP in the identificational cleft, whose data we repeat here:

- (31) a. [[John-i Mary-lul manna-n] kes-nun] kongwon(eyse)-i-ta  
 John-NOM Mary-ACC meet-MOD KES-TOP park.at-COP-DECL  
 ‘(lit.) When John met Mary was at the park.’  
 b. \*[kongwen-(eyse)]<sub>PP</sub>-ka [John-i Mary-lul manna-n kes]-i-ta  
 park-at-NOM [John-NOM Mary-ACC meet-MOD KES]-COP-DECL

Since the predicational cleft only requires the precopular element to be predicative, regardless of its referential property, we can have a locative element in the pivot clause as well as an adverbial element as given in the following:

- (32) [[John-i Mary-lul manna-n] kes-nun] ecey-i-ta  
 John-NOM Mary-ACC meet-MOD KES-TOP yesterday-COP-DECL  
 ‘(lit.) When John met Mary was yesterday.’

This event denoting KES clause here is in a predicative relation with the adjunct *ecey* ‘yesterday’. That is, the semantics the analysis generates is something like the following:

- (33) 
$$\left[ \text{RELS} \left\langle \left[ \begin{array}{l} \text{PRED } meet\_rel \\ \text{ARG0 } e1 \\ \text{ARG1 } j \\ \text{ARG2 } m \end{array} \right], \left[ \begin{array}{l} \text{PRED } yesterday\_rel \\ \text{ARG0 } t1 \\ \text{ARGF1 } e1 \end{array} \right], \left[ \begin{array}{l} \text{PRED } predicative\_rel \\ \text{ARG1 } e1 \\ \text{ARG2 } t1 \end{array} \right] \right\rangle \right]$$

We have shown that clefts are like relative clauses. It is then natural to expect that clefts are also involved in long distance dependency just like relative clauses since the analysis takes the internal structure of the cleft as that of a relative clause. In particular, the gap in the cleft clause is an argument (cf. See [?]). This means in the present analysis, the argument-gapped cleft and adjunct gapped cleft are thus different: only the former is treated as a kind of unbounded dependency, as we have seen earlier. Let’s consider similar data again:

- (34) a. John-i [Mary-ka \_\_\_ ilkessta-ko] sayngkakha-n kes-un  
 John-NOM Mary-NOM read-COMP think-MOD KES-TOP  
 i chayk-i-ta  
 this book-COP-DECL  
 ‘The one that John thinks Mary read is this book.’  
 b. John-i [Mary-ka i chaky-ul ilkessta-ko] malha-n kes-un  
 John-NOM Mary-NOM this book read-COMP said-MOD KES-TOP  
 i kos-(eyse)-i-ta  
 this place-COP-DECL  
 ‘The place that John said Mary read this book is in this place.’

Though the precopular in (34a) expression is linked to the argument gap in the embedded clause, the adjunct precopular one in (34b) modifies only the matrix predicate ‘said’.

### 3.2 Eventual Cleft

As noted earlier, the event cleft construction is a construction where the entire matrix clause is headed by the nominalizer KES followed by the copula. Even though the KES here nominalizes the whole sentence, corpus search shows us that the event cleft commonly is preceded by a temporal or reason adverb that introduces this event clause.

- (35) a. ku ttay, saken-i ilena-n kes/\*iyu-i-ta  
 then accident occur-MODKES/reason-COP-DECL  
 ‘And then the accident occurred.’
- b. kuliko nase, hyung-i os-ul twici-nun kes-i-ess-ta  
 and after brother-NOM clothes-ACC search-MOD KES-COP-PAST-DECL  
 ‘After that, brother searched the clothes.’

Such an event cleft clause does not occur in the beginning of context as in English examples like *It is then that Tom ate the big apple*. It appears that the event cleft sentence is interpreted based on the speaker’s prior knowledge. This semantic relation can be ‘cause, conclusion, reason, or explanation’. Following [?], we assume that such relations are subtypes of the semantic relation ‘inference’. That is, the interpretation of this construction is inferred from the speaker’s prior knowledge. To reflect these properties, we assume that the copula here is minimally different from the copula in the predicational or identificational cleft in that the first argument is an unrealized *pro* element linked to the speaker’s prior knowledge.

- (36) Eventual:
- $$\left[ \begin{array}{l} \langle i\text{-ta} \rangle \\ \text{ARG-ST} \left\langle \text{XP} \left[ \begin{array}{l} \textit{pro} \\ \text{IND } i \end{array} \right], \text{NP} \left[ \begin{array}{l} \text{NFORM } \textit{kes} \\ \text{IND } e1 \end{array} \right] \right\rangle \\ \text{SEM | RELS} \left\langle \left[ \begin{array}{l} \text{PRED } \textit{inference\_rel} \\ \text{ARG1 } i \\ \text{ARG2 } e1 \end{array} \right] \right\rangle \end{array} \right]$$

This lexical entry tells us that the two arguments selected by this peculiar copula are eventually related by the semantic relation *inference\_rel*. Even though the first argument functions as *pro* and thus will not be realized in syntax, the argument is linked to the cleft clause by this semantic/pragmatic relation. This lexical entry will then allow a structure like the following:

(37)

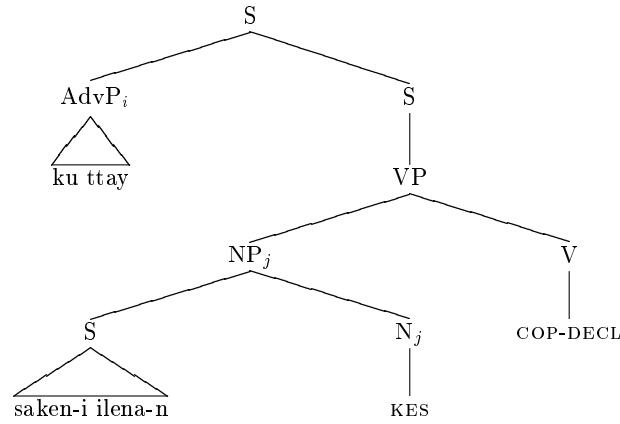

The lexical constraints of the eventual copula insures that we have the following MRS for this sentence:

$$(38) \left[ \begin{array}{l} \left[ \begin{array}{l} \text{PRED } the\_moment\_rel \\ \text{ARG0 } m \\ \text{ARG1 } e1 \end{array} \right], \left[ \begin{array}{l} \text{PRED } pro\_rel \\ \text{ARG1 } i \end{array} \right], \left[ \begin{array}{l} \text{PRED } inference\_rel \\ \text{ARG1 } i \\ \text{ARG2 } e1 \end{array} \right] \\ \left[ \begin{array}{l} \text{PRED } accident\_rel \\ \text{ARG1 } k \end{array} \right], \left[ \begin{array}{l} \text{PRED } occur\_rel \\ \text{ARG0 } e1 \\ \text{ARG1 } k \end{array} \right] \end{array} \right]$$

As given in the MRS, the sentence means that there occurred an accident at a given moment. This event is linked to the speaker's prior knowledge by the 'inference' relation.

## 4 Results of the Implementation

The analysis we have presented so far has been incorporated in the typed-feature structure grammar HPSG for Korean (Korean Resource Grammar) aiming at working with real-world data (cf. [?] and [?]). To test its performance and feasibility, it has been implemented into the LKB (Linguistic Knowledge Building).<sup>16</sup> The test results give the proper syntactic as well as semantic structures for the three types of Korean cleft constructions.

Figure 1 and 2 are the parsing results of the two main types of cleft constructions we have seen so far. The small boxes in the figures indicate parsed tree structures whereas the big boxes denote the semantic representations.

Consider Figure 1 first. In terms of the syntactic structure, the grammar generates the structure in which KES combines with the relative clause 'John read

<sup>16</sup> The current Korean Resource Grammar has 394 type definitions, 36 grammar rules, 77 inflectional rules, 1100 lexical entries, and 2100 test-suite sentences, and aims to expand its coverage on real-life data.

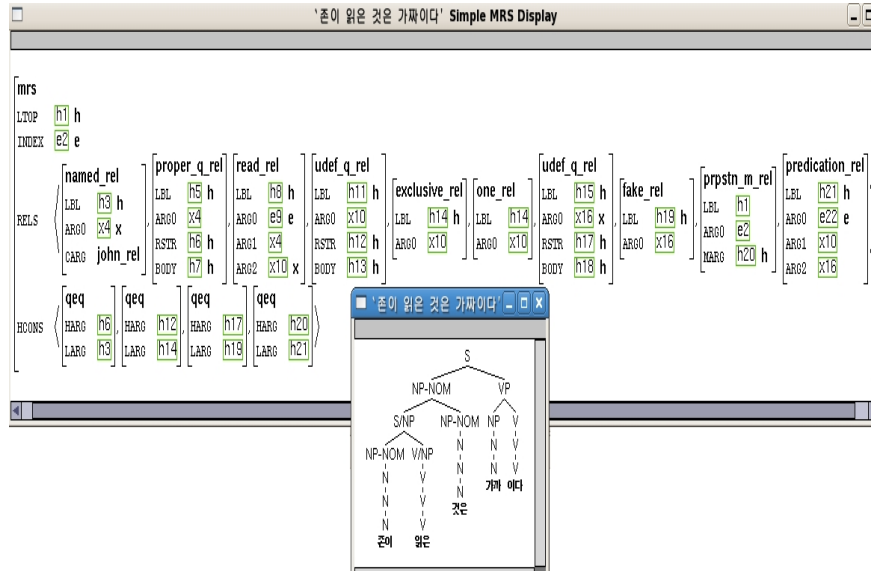

Fig. 1. Parsed Trees and MRS for Predicational cleft (1a): ‘What John read is a fake’

\_\_\_’. This functions as the subject. The copula verb selects this cleft-clause like element as its subject and the noun ‘fake’ as its predicative element. We can notice here that the MRS the grammar generates provides enriched information of the phrase. The value of *LTOP* is the local top handle, the handle of the relation with the widest scope within the constituent. The attribute *RELS* is basically a bag of elementary predications (EP) each of whose value is a *relation*.<sup>17</sup> Each of the types *relation* has at least three features *LBL*, *PRED* (represented here as a type), and *ARG0*. For the proper noun John, it has two related EPs: *named\_rel* and *proper\_q\_rel*. The relation *udef\_q\_rel* is related to the projection of the common noun KES not combining with any specifier, whereas *exclusive\_rel* concerns the topic marker *-nun*.<sup>18</sup> The meaning of KES is represented as *one\_q\_rel*. We can observe that the EP *read\_rel* has two ARGs: one is linked to the argument of *named\_q\_rel* and the other linked to *one\_rel* (X10). This indicates that we have the meaning ‘John reads one’. The relation *predication\_rel* selects two arguments: X10 and X16. The second value X16 is linked to ‘fake’. The parsing system thus gives us an enriched semantics for the predicational cleft sentence.

Figure 2 for the identificational cleft is similar to the predicational one. The syntactic structure in the small box shows us that ‘this book’ functions’ as the

<sup>17</sup> The attribute *HCONS* is to represent quantificational information. See [?].

<sup>18</sup> Korean common nouns do not require a determiner to project an NP. Even though a determiner is not available, we need to express an underspecified quantification on the noun in order to make the semantics compatible with the semantic output of other languages, and to make scope restrictions work. Such a move is essential in deep processing aimed at multilingual applications.

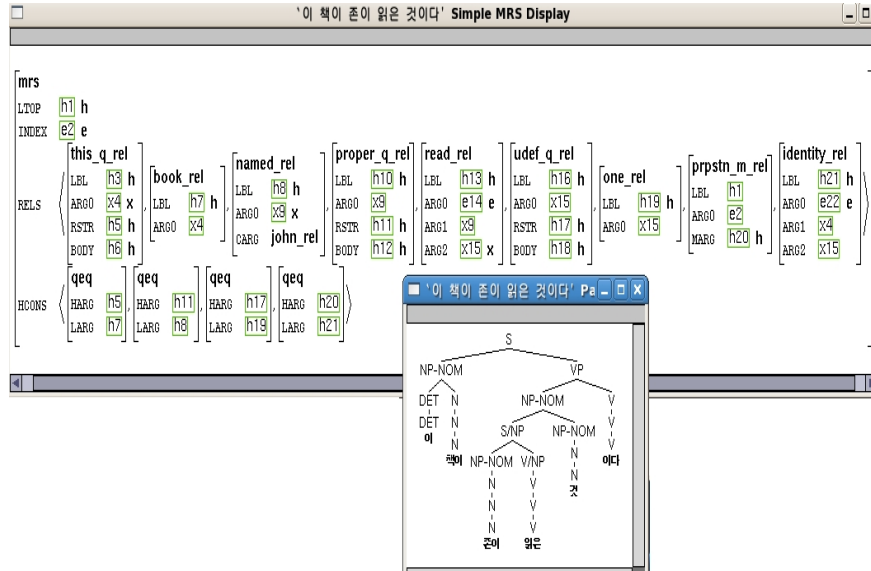

**Fig. 2.** Parsed Trees and MRS for Identificational cleft (1b): ‘This book is what John read’

subject whereas as the cleft clause as the precopular complement. In the MRS representation, we can observe that *identity\_q\_rel* selects two arguments, ARG1 and ARG2. The first argument ARG1 is linked to the argument of the book (*book\_rel* whereas the second argument ARG2 is identical with the argument of KES (*one\_rel*).

Now let us consider the results of parsing an event cleft. Figure 3 is the results of parsing the sentence. The syntactic structure gives us the information that *ku ttay-ey* is modifying the matrix sentence which is missing the subject. We assumed that the subject is lexically a pronoun not realized in syntax. In terms of semantics, this unrealized pronoun (x9) is in an ‘inference’ semantic relation with the proposition (e16) ‘the accident occurred’. The inference relation is context-determined.

## 5 Conclusion

We have seen that there are three types of Korean clefts constituted of a cleft clause, a focused expression, and a copula. These predicational, identificational, and eventual cleft are closely related to corresponding copula constructions.

The proper syntactic and semantic treatment of cleft constructions has been challenges even to theoretical aspects. Based on the simple assumption that KES is treated as a nominal element as a morphosyntactic category but refers to either an individual or an event. The pronoun KES in the cleft clause refers to an individual entity as in the relative clause. Given these basic assumptions, we

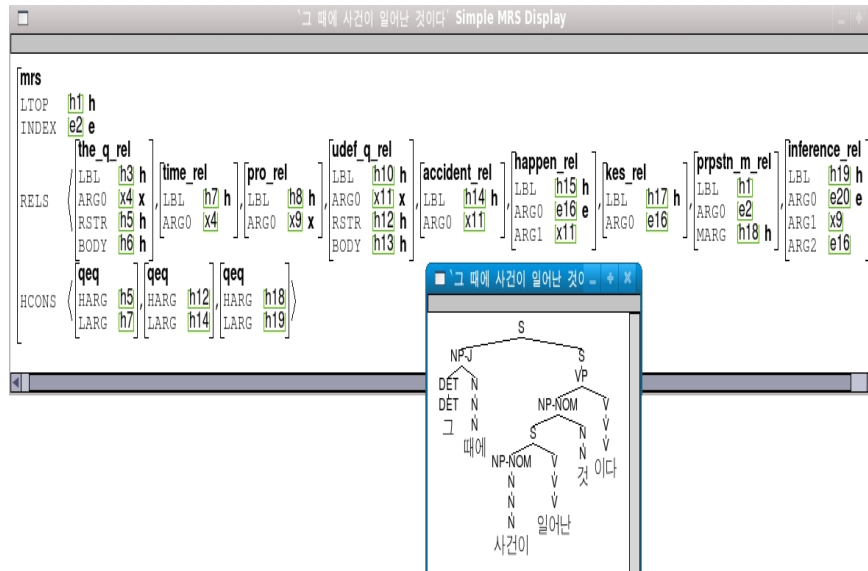

**Fig. 3.** Parsed Trees and MRS for Identificational cleft (1b): ‘At the moment, the accident occurred.’

have built a constraint-based grammar couched upon HPSG. The grammar we have built within a typed-feature structure system and well-defined constraints, eventually aiming at working with real-world data, has been implemented in the LKB (Linguistic Knowledge Building) system. We have shown that the grammar can parse the appropriate syntactic and semantic aspects of the three types of cleft constructions. Even though the test data set we used in checking the feasibility of the system is limited, the test results shows us that the grammar, built upon the typed feature structure system, is efficient enough to build semantic representations for the complex cleft constructions.